

DYNAPAC

Part of the Atlas Copco Group

CP274

Pneumatic rollers



Technical data

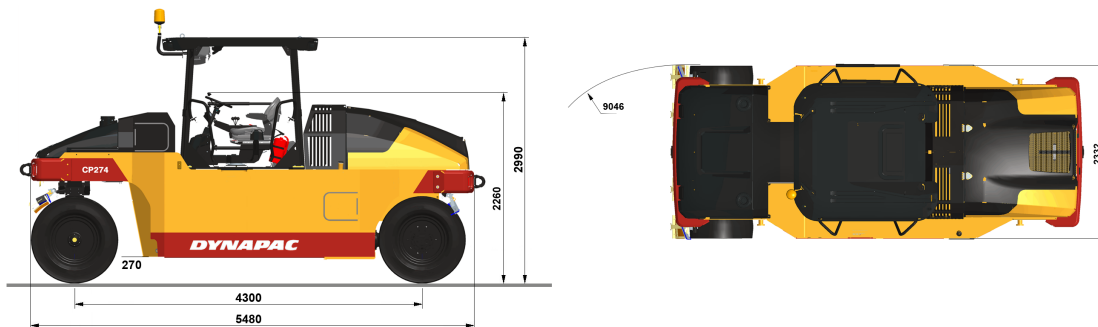

Masses	CP274
Operating mass (incl. ROPS)	10,800 kg
Mass with wet sand ballast	17,000 kg
Mass with max. ballast	27,000 kg
Compaction	
Rolling width	2,300 mm
Tyre overlap	42 mm
Wheel loads, without ballast	1,200 kg
Wheel loads, with wet sand ballast	1,900 kg
Wheel loads, with max. ballast	3,000 kg
Tyre pressure, min	250 kPa
Tyre pressure, max	850 kPa
Tyre type (smooth)	13/80 R20
Water spray system, type	Pressurized
Water spray system, tank capacity	415 l
Water spray system, spray nozzle	one per tyre
Ballast volume	3 m ³
Traction	
Speed low	7 km/ h
Speed high	23 km/ h
Speed high (EEC countries)	20 km/ h
Engine	
Manufacturer/ Model	Cummins QSB 4.5 T3
Type	Water cooled turbo Diesel with After Cooler
Rated power, SAE J1995	82 kW (110 hp) @ 2,200 rpm
Fuel tank capacity	210 l
Electrical system	24V
Hydraulic system	
Driving	Axial piston pump with variable displacement. Axial piston motors (2) with variable displacement.
Steering	Axial piston pump with variable displacement.
Service brake	2 multidisc brakes on rear wheels activated by pedal.
Parking/ Emergency brake	Failsafe multidisc brakes in both gear boxes.

Find your local dealer at www.dynapac.com

We reserve the right to change specifications without notice. Photos and illustrations do not always show standard versions of machines. The above information is a general description only, all informations are supplied without liability.